

AD-120D

INSTALLATION AND OPERATION MANUAL

ADVISION

Mixer Amplifiers with Mp3/FM/BT



Caution: Please read this manual carefully before operating
Damage caused by misuse is not covered by the warranty





Feature:

- Compact mini size public address amplifier
- Tabletop mixer amplifier with Mp3 player, FM radio & blue tooth
- Rate power output at 30W, 60W to 120W
- Speaker output of 100V or 70V & 4 Ohm-8 Ohm-16 Ohm
- Mp3 player with USB/SD input on front panel, IR remote control for Mp3 player, FM radio and blue tooth
- LED indicators for power, clip, protect and signal
- Mic1 of balanced XLR input with dipswitch of phantom power on/off & highest VOX priority on/off
- Mic/line 2-3 switchable input unbalanced 6.3mm jack
- Line 1-2 input of RCA input and one RCA line output
- Telephone input with secondary priority and MOH (Music on Hold)
- Volume control for Mic1-3, line1-2, TEL, bass/treble and master
- Complete amplifier protection includes short-circuit, clip, overload and high temp
- 230V AC & 24V DC both power supply system

Specification:

Model	EA-30	EA-60	EA-120
Description	Mixer Amplifier with USB/SD/FM/Blue Tooth		
Rated Power Output	30W	60W	120W
Speaker Outputs	100V or 70V & 4 Ohm-8 Ohm-16 Ohm		
Connector	Mic1 input by balanced XLR with phantom power & VOX highest priority Mic/line switchable input 2-3 unbalanced 6.3mm jack Telephone input with secondary priority and MOH (Music on Hold) Line1-2 inputs by RCA; Line output by RCA		
Input	MIC1-3: 5-8mV, 600Ω; Line, 150-470mV, 10KΩ, unbalanced RCA		
Line Out	0.775(0dBV)		
Frequency Response	60Hz-15kHz(±3dB)		
S/N Ratio	Line ≥ 85dB, Mic ≥ 72dB		
THD	Less than 0.5%		
Protection	Short-circuit, clip, overload and high temp protection		
Power Consumption	60W	100W	200W
Power Supply	230V AC & 24V DC; 50-60Hz		
Dimension	320×210×90mm		
Weight	3.6kg	4.1kg	4.7kg

Rear Panel:



SAFTY WARNINGS!

1. Read and keep these instructions.
2. Heed all warnings and follow all instructions.
3. Do not use this apparatus near water.
4. Do not block any ventilation openings. Install in accordance with the manufacturer's instructions.
5. Do not install near any heat sources such as radiators, heat registers, stoves, or other apparatus that produce heat.
6. Do not defeat the safety purpose of the polarized or grounding-type plug. A polarized plug has two blades with one wider than the other. A grounding type plug has two blades and a third grounding prong. The wide blade or the third prong is provided for your safety. If the provided plug does not fit into your outlet, consult an electrician for replacement of the obsolete outlet.
7. Protect the power cord from being walked on or pinched particularly at plugs, convenience receptacles, and the point where they exit from the apparatus.
8. Only use attachments/accessories specified by the manufacturer.
9. Use only with the cart, stand, tripod, bracket, or table specified by the manufacturer, or sold with the apparatus. When a cart is used, use caution when moving the cart/apparatus combination to avoid injury from tip-over.
10. Unplug this apparatus during lightning storms or when unused for long periods of time.
11. Refer all servicing to qualified service personnel. Servicing is required when the apparatus has been damaged in any way, such as power-supply cord or plug is damaged, liquid has been spilled or objects have fallen into the apparatus, the apparatus has been exposed to rain or moisture, does not operate normally, or has been dropped.
12. This appliance shall not be exposed to dripping or splashing water and that no object filled with liquid such as vases shall be placed on the apparatus.
13. Plug this apparatus to the proper wall outlet and make the plug to be disconnected readily operable.
14. Main plug is used as disconnected device and it should remain readily operable during intended use. In order to disconnect the apparatus from the mains completely, the mains plug should be disconnected from the mains socket outlet completely.
15. **WARNING:** To reduce the risk of fire or electric shock, do not expose this apparatus to rain or moisture.
16. An appliance with a protective earth terminal should be connected to a mains outlet with a protective earth connection.

WARNING!

TO PREVENT FIRE OR SHOCK HAZARD, DO NOT USE THE PLUG WITH AN EXTENSION CORD, RECEPTACLE OR OTHER OUTLET UNLESS THE BLADES CAN BE FULLY INSERTED TO PREVENT BLADE EXPOSURE.

TO REDUCE THE RISK OF FIRE OR ELECTRIC SHOCK, DO NOT EXPOSE THIS APPLIANCE TO RAIN OR MOISTURE.

TO PREVENT ELECTRICAL SHOCK, MATCH WIDE BLADE PLUG TO WIDE SLOT, FULLY INSERT.



The lightning flash with arrowhead symbol, within an equilateral triangle, is intended to alert the user to the presence of uninsulated "dangerous voltage" within the product's enclosure that may be of sufficient magnitude to constitute a risk of electric shock to persons.

CAUTION

RISK OF ELECTRIC SHOCK
DO NOT OPEN

WARNING: TO REDUCE THE RISK OF ELECTRIC SHOCK, DO NOT REMOVE COVER (OR BACK). NO USER SERVICEABLE PARTS INSIDE. REFER SERVICING TO QUALIFIED SERVICE PERSONNEL.



The exclamation point within an equilateral triangle is intended to alert the user to the presence of important operating and maintenance (servicing) instructions in the literature accompanying the appliance.

INTRODUCTIONS

Description

The Mixer Amplifier with MP3, FM tuner & blue tooth, its rated power output from 30W, 60W to 120W, it is ideal for school, super market, bank, hotel BGM and speech use. It is all in one solution with two sources, pre amplifier and mixer power amplifier into one unit, which is economy but of high reliable performance.

It integrates 2 audio sources into a mixer amplifier, plus Mic1(XLR) and Mic/Line input 2-3 (6.3mm Jack), two line inputs, one Tel input and one line output. Mic1 VOX with highest priority except Tel input. One USB and one SD slots on front provide easy access and operation for installer and end-user.

The amplifier is designed with complete protection of overload, short circuit and high temp to avoid any damage.

These amplifiers are suitable for applications in bank, mosque, school, hotel, restaurant, theme centers and shopping center.

Features

- Compact mini size public address amplifier
- Ideal for classroom sound system use
- Built-in 100V/70V transformer technology
- Tabletop amplifier with Mp3 player, FM radio & blue tooth
- Rate power output at 30W, 60W to 120W
- Speaker output of 100V or 70V & 4Ohm-8 Ohm-16 Ohm
- Mp3 player with USB/SD input on front panel, IR remote control for Mp3 player, FM radio & blue tooth
- LED indicators for power, clip, protect and signal
- Mic1-3 and line 1-2 and telephone input. Mic1 of balanced XLR input with +48V phantom power on rear panel. Mic/Line switchable input 2-3 unbalanced 6.3mm phone jack input. Line 1-2 input of RCA input and one RCA line output. Telephone input with VOX priority and MOH (Music on Hold)
- Volume control for Mic1-3, line1-2, Mp3/FM, bass/treble and master
- With short-circuit, clip, overload and high temp protection
- 110V AC to 230V AC or 115V &24V DC both power supply system

FRONT PANEL

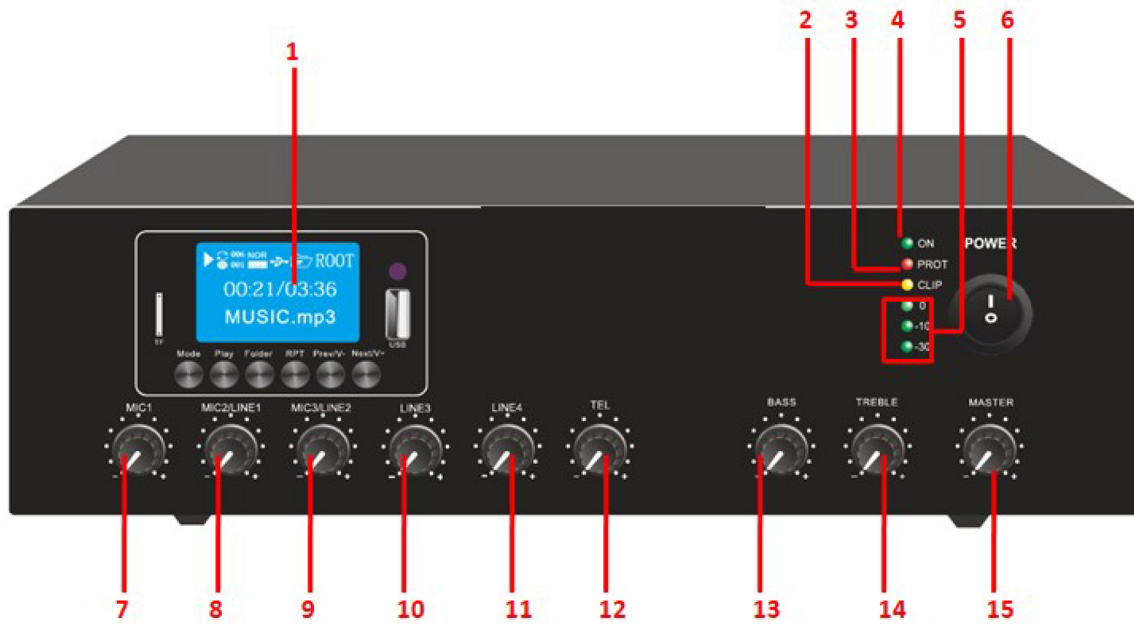

1. Mp3/FM/Blue tooth media player module.
2. Power indicator.
3. Protection Indicator.
4. Clip Indicator.
5. Output Level Meters.
6. AC power switch.
7. Mic1 Attenuator.
8. Mic/Line Input 2 Attenuator.
9. Mic/Line Input 3 Attenuator.
10. Line Input 3 Attenuator.
11. Line Input 4 Attenuator.
12. Tel Input Attenuator
13. Bass
14. Treble
15. Master Volume Control

REAR PANEL

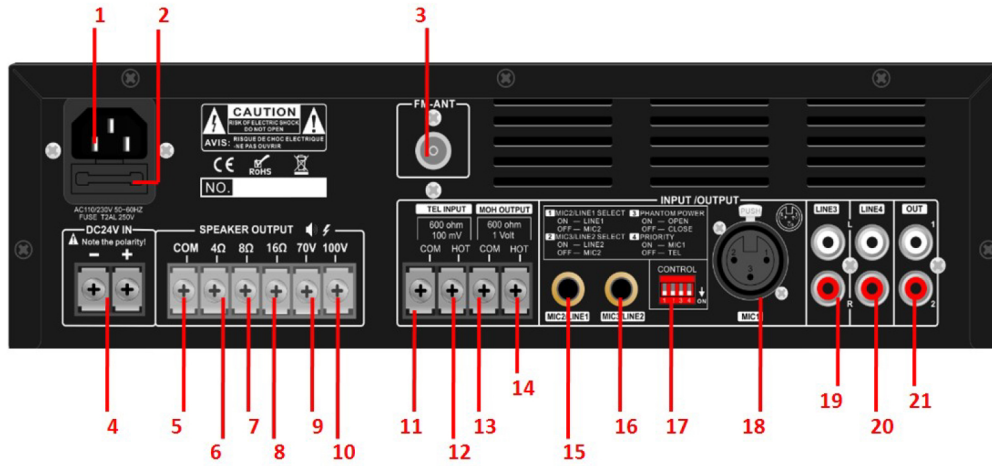

- | | |
|-------------------------------|---|
| 1. AC Power Socket. | 12. Tel input HOT (+), 600 Ohms, 1 Volt. |
| 2. AC fuse | 13. MOH output COM (-). |
| 3. FM antenna | 14. MOH output HOT (+). |
| 4. 24V DC Battery Input. | 15. Input 2 Mic/Line Selector. |
| 5. Speaker output COM. | 16. Input 3 Mic/Line Selector. |
| 6. Speaker output 4 Ohm (+). | 17. Dipswitch for MIC/LINE selector, phantom power and Mic1 priority. |
| 7. Speaker output 8 Ohm (+). | 18. Microphone 1XLR input. |
| 8. Speaker output 16 Ohm (+). | 19. Line 3 Input. |
| 9. Speaker output 70V (+). | 20. Line 4 Input. |
| 10. Speaker output 100V (+). | 21. Line Output. |
| 11. Tel input COM (-). | |

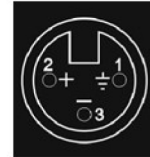

Male XLR-3P:
 Pin1-Ground
 Pin2-Positive signal
 Pin3- Negative signal

AMPLIFIER OPERATION GUIDANCE

100V Line System

For 100V line systems, connect the amplifier to the first speaker in the system using double-insulated speaker wire which has adequate current rating to handle the total output of the amplifier.

Connect the “100V” output terminal to the positive (+) connection of the speaker and “COM” output to the negative (-) connection of the speaker. Connect further speakers in parallel to the first speaker with all positive terminals and connected together and all negative terminals connected together as shown below.

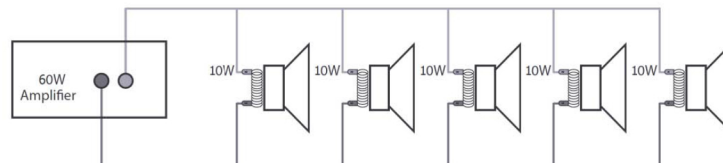

A 100V line speaker system can comprise of many speakers connected together. The determining factor for how many speakers can be used on a single amplifier is the power rating. For most purposes, it is advised to connect as many speakers as needed with a combined wattage of no more than 90% of the amplifier’s output power rating.

The terminals of a 100V speaker are connected to a transformer and in some cases, this transformer may be “tapped” for different power ratings. These tapings can be used to adjust the wattage (and output volume) of each speaker in the system to help achieve

the ideal total power of the system for the amplifier.

The mixer amplifier is featured of 6 speaker zone outputs, either one of six zone or total six zone power loading shall be equivalent or no higher than the rated power of the amplifier.

Speaker Terminals

These terminals are offering 3 low voltage outputs 4Ω, 8Ω, 16Ω depending on your speaker combination. A 70V/100V commercial output is also available. Please note that one wire only should be connected to COM screw and one wire to the selected impedance or voltage. **Multiple combinations cannot be done at the output level.** Four different types of connections are provided. The low impedance section: 4Ω, 8Ω, 16Ω is designed for a small amount of speakers to be connected to your amplifier. The 70V/100V section is especially designed for a multiple speaker distribution. When using the 70V/100V output, speakers have to be equipped with 70V/100V transformer. The maximum amount of speakers to be placed on your distribution line is in relation to the power allocated to each speaker. The total wattage set on the secondary side of the transformers on your speaker line must not exceed the maximum RMS output power: 30W, 60W or 120W. Failure to respect this may cause permanent damage to the amplifier.

Speaker Connections

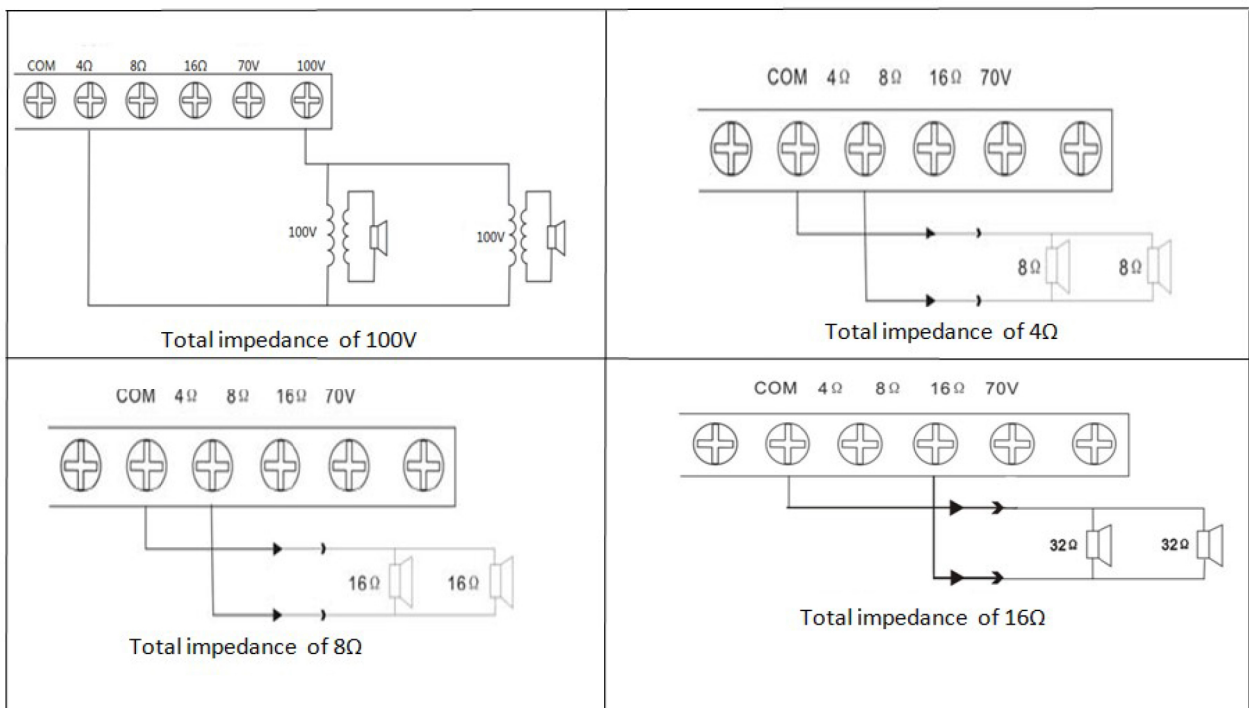

Operation Steps

- When all connections to the amplifier are made, turn all rotary controls down and switch on the power and a power “ON” LED will illuminate. Turn BASS and TREBLE controls to the 12 o’clock position (pointing straight up) and turn MASTER rotary control up part way for testing.
- Ensure a signal is being fed to one of the line inputs 1, 2, 3, 4 or 5 and gradually increase the volume control for that channel until the output is heard through the speakers. Turn up the MASTER to the maximum required volume level and reduce the channel volume control if necessary.
- Note: The initial test can be made using the built-in USB/SD/FM audio player. The output of the amplifier is represented on the level meter LEDs and care should be taken that the Red “0” LED is only lit momentarily during use. Anything longer than a short flash of this LED may be indicating distortion or clipping of the output signal and the MASTER should be turned down.
- If a microphone is connected to MIC1 input, make sure it is switched on and if it requires phantom power, make sure this feature is enabled. Gradually increase its volume control whilst speaking into the microphone until the required volume level is reached. The microphone should not be able to “hear” the speakers, which can cause feedback (squealing or howling noise).

- If the VOX feature is enabled, audio playback through channels 2-5 will be reduced in volume automatically when speaking into MIC 1, use its attenuator to increase or decrease the mute level.
- In addition to channel and MASTER volume controls, there are BASS and TREBLE EQ controls to adjust the tone of the overall output. At the 12 o'clock position, these controls are applying no effect to the signal (no boost or cut). Moving the BASS control clockwise boosts the low frequencies in the audio, whilst moving it anticlockwise will cut these low frequencies. Likewise, moving the TREBLE control clockwise boosts the high frequencies in the audio, whilst moving it anticlockwise will cut these high frequencies. Adjust these EQ controls to suit the type of audio signal or compensate for the room acoustics.

Media Player

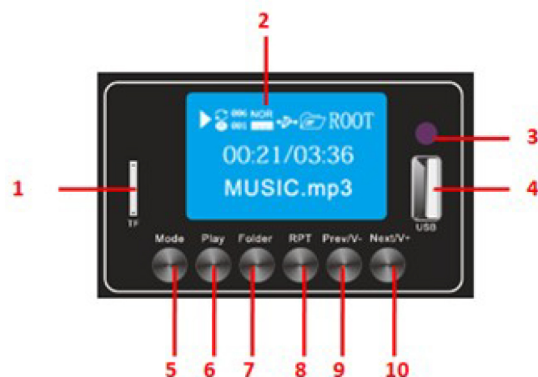

1. TF card input
2. LED display
3. IR sensor
4. USB input
5. Mode to select MP3/BL/FM
6. Play
7. Folder
8. RPT repeat
9. Previous & volume- decrease
10. Next & volume + increase

The mixer-amplifiers are built-in a built-in media player which includes Mp3/FM/Bluetooth. Pressing the Mode button to switch the media player among Mp3/FM/Bluetooth according to the LED display, where there is one IR remote control enable to operate the media player remotely around 10 to 30 meters, this media player output volume control also could be controlled by the "TEL" volume knob.

Bluetooth

The Bluetooth function allows connection of a smart phone or tablet to the media player section for playback of stored files or streamed digital audio. In order to enable this function, it will be necessary to pair the sending device to the receiver as follows.

1. Open the Bluetooth settings menu on the smart phone or tablet (or other sending device)
2. Scan for Bluetooth devices and look for it in the list of available devices (ensure that the amplifier is powered on and within 30-50 meters reception range)
3. Select the blue tooth and the sending device should confirm that it is connected as an audio device
4. Play audio from the sending device, ensuring that volume controls are not turned down/muted
5. Turn up the MEDIA volume control on the amplifier to the required level

If the Bluetooth signal is lost, it may be necessary to re-select the Bluetooth on the sending device.

The Previous, Next and Play/pause buttons will operate in Bluetooth as remote playback controls. Holding the Previous track or Next track buttons will adjust the output volume of the player.

USB/SD Playback

Push a USB pen drive into the USB port and/or an SD card into the SD card input.

Press the CD/USB/SD button to ensure that the player is set to play from the required memory device. Press the PLAY/PAUSE button to play the current track and press again to pause as needed.

Searching and playback of tracks is the same as described above for the CD player

FM Tuner

Press the FM select button to switch to the FM tuner function. Use the Previous or Next buttons to select a stored channel.

Tuning and storing stations

Use the Forward/Reverse seek buttons to manually tune the frequency in steps of 0.05MHz

Alternatively, press and hold the Forward/Reverse seek buttons to auto search for available stations.

Upon finding a station, the auto search will stop, giving the option to store this station.

At this point, pressing the PLAY/PAUSE button will flash a "00" channel number in the display.

Use the Previous/Next buttons to select an appropriate channel memory.

Press PLAY/PAUSE again to confirm and store the station into the selected channel memory.

Auto search can be stopped at any time by pressing the Forward/Reverse seek buttons.

Music on Hold

This output will feed music on your telephone system or PABX for people waiting to be answered. A dedicated input should be available on your telephone system. Please refer to a qualified technician if you can't identify this input. Outgoing signal should be connected to G and H.

Telephone Paging Input

This special TEL input will allow you to page in your PA system using your own telephone set or PABX system. At the end of the announcement, the system will return to its normal operation. The telephone paging input with priority except EMC (fire alarm) input. Final volume adjustment will be made with the Tel Paging volume control located on front panel.

CONNECTION DIAGRAMS

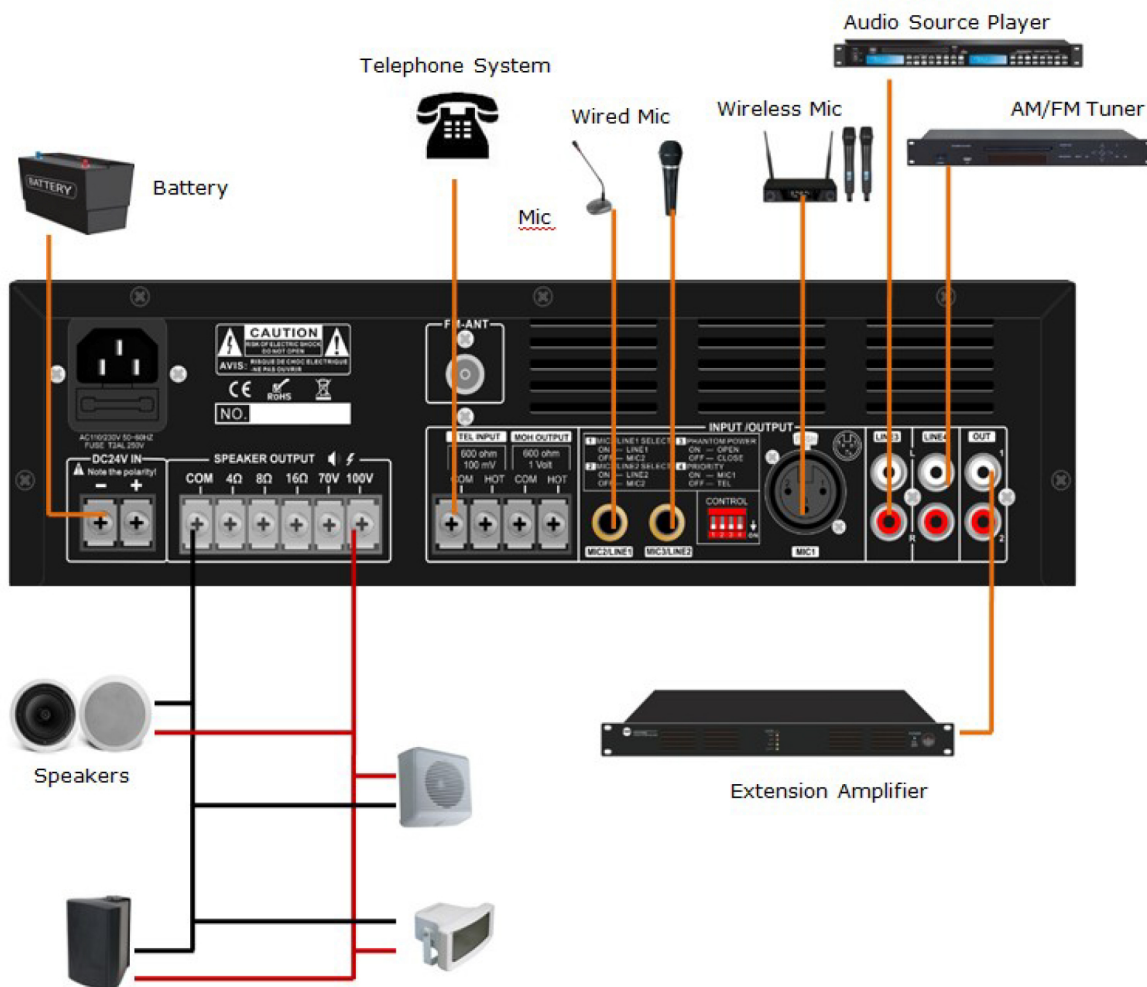

SPECIFICATION

Model	EA-30	EA-60	EA-120
Description	Mixer Amplifier with USB/SD/FM/Blue Tooth		
Rated Power Output	30W	60W	120W
Speaker Outputs	100V or 70V & 4Ohm-8 Ohm-16 Ohm		
Connector	Mic1 input by balanced XLR with +48V phantom power Mic/Line switchable 2-3 inputs unbalanced 6.3mm phone jack Line1-2 inputs by RCA; Line output by RCA		
Attenuation	Microphone1-3, line1-2 and Mp3/FM, bass/treble and master		
Input	MIC1-3: 5-8mV, 600Ω; Line, 150-470mV, 10KΩ, unbalanced RCA		
Line Out	0.775(0dBV)		
Frequency Response	60Hz-15kHz(±3dB)		
S/N Ratio	Line ≥ 85dB, Mic≥ 72dB		
THD	Less than 0.5%		
Protection	short-circuit, clip, overload and high temp protection		
Power Consumption	60W	100W	200W
Power Supply	110V AC to 230V AC or 115V &24V DC; 50-60Hz		
Dimension	320×210×90mm		
Weight	3.6kg	4.1kg	4.7kg

TROUBLESHOOTING

No power LED on control panel	Ensure IEC lead is in good condition and connected properly
	If 12Vdc power input is being used, check battery is charged
	Check mains inlet fuse
	Ensure POWER switch is on
Power LED is on but no other LEDs and no output	Check input signals and condition of input connection leads
	Check MASTER, MIC, LINE IN or MEDIA controls are turned up
Power light and output LEDs lighting but no output	Check speaker output terminals are connected correctly
	Check speakers are working (test on another amp if available)
Bluetooth cannot connect	Ensure that Bluetooth is enabled on sending device
	Ensure that the sending device is within Bluetooth range (5-10m)
	Check that blue tooth is the connected device
	If there are more than one blue tooth devices, check each in turn
No audio from connected Bluetooth device	Ensure that volume controls are not turned down on sending device
	Check volume and Play/Pause buttons in case Bluetooth is muted
USB player will not play audio from media	Press PLAY on transport controls
	Check memory device is connected properly (remove and re-insert)
	Check file types – standard compressed digital audio files required
	Check memory device works on a PC or Mac for standard playback
Output is very loud or distorted	Check level of input signal is not too high
	Reduce MIC, LINE IN, MEDIA and/or MASTER level
	Ensure Hi-Z line level input(s) not connected via MIC input
Output is working but at very low level	Check input audio source level is not too low
	Increase MIC, LINE IN, MEDIA and/or MASTER level
	Check for quiet recording of media files on USB
Feedback from microphone	Face microphone away from speakers and monitors
	Turn down MIC and/or MASTER level
Amplifier overheating	Ensure cooling vents are clear from debris and dust
	Check that 8Ω speakers are not connected to 100V terminals
	Ensure total 100V speaker wattage is lower than amplifier rating
	Ensure that 100V and 8Ω speakers are not both connected
	Ensure that total load connected to 8Ω output is not less than 8Ω

SERVICE

Ensure the problem is not related to operator error, or system devices that are external to this unit. Information provided in the troubleshooting portion of this manual may help with this process. Once it is certain that the problem is related to the product contact your warranty provider as described in the warranty section of this manual.

WARRANTY

Warranty terms of global three years. While the term and warranty may vary by country and may not be the same for all products. Terms and conditions of warranty for a given product may be determined first by locating the appropriate country which the product was purchased in, then by locating the product type.